



E05-AC40153



TECHNICAL DATA

ITEM DESCRIPTION DOUBLE BASKET

ITEM CODE E05-AC40153

DIMENSIONS W X H (MM)
200 X 320

FINISHES P00 - CHROME

TECHNICAL DRAWINGS

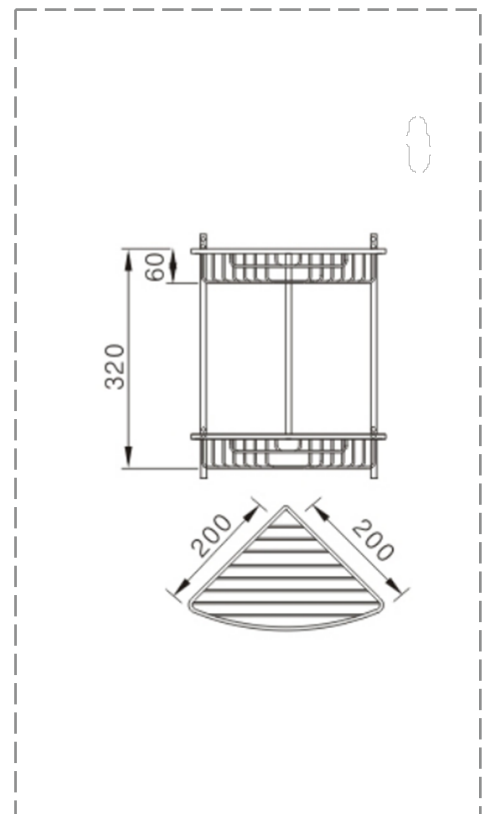

TECHNOLOGY - CERTIFICATION

PRODUCT TYPE : WALL MOUNTED

MATERIAL : BRASS

STANDARD : CE STANDARD